

OPERATION MANUAL

MCB SLAVE SERIAL INTERFACE MC11S



Part No. Z1-000-382, IA002092

The specifications of this product and the contents of this Operation Manual are subject to change without prior notice.

Copyright© 1992-2000 Kikusui Electronics Corporation

All rights reserved.

Printed in Japan

◆ Receiving Inspection

Upon receipt of the MC11S interface, please immediately inspect it to check that it has not been damaged when in transportation. Also check that the accessories are not missing.

◆ Accessories

The following accessories accompany the MC11S interface.

- Dummy socket for MCB OUT connector 1 (installed)
- Special MCB cable (1 meter) 1
- Installation bolts 2
- Operation manual 1 copy

- Caution** • Do not touch the electrically conductive parts of the MC11S interface.
If you do, internal electronic parts can be damaged by static electricity.

Keep this manual near the MC11S interface so that you can refer to this manual whenever you want to.

TABLE OF CONTENTS

	PAGE
Chapter 1. GENERAL	1
1.1 Introduction	1
1.2 Applicable Series	1
Chapter 2. PREPARATION	2
2.1 Installing the MC11S	2
2.2 Description of Connectors and Switch	3
2.3 Setting the Short Plugs	3
2.4 Loading/Unloading with Terminator Resistor	4
2.5 Connecting the Interface Boards with Cables	5
2.6 Setting the Device Address	5
Chapter 3. STARTUP AND TEST	6
3.1 Turning-on Power	6
3.2 Running a Test Program	7
Chapter 4. CHECKUP BEFORE ORDERING REPAIR	8
Chapter 5. SPECIFICATIONS	9
5.1 MCB (Slave Function) Section	9
5.2 Ambient Conditions	10
5.3 Withstanding Voltage and Insulation Resistances	10
5.4 Dimensions and Weight	11
5.5 Accessories	11
Appendix: EXTERNAL VIEWS AND OVERALL DIMENSIONS	12

Chapter 1. GENERAL

1.1 Introduction

The MC11S is a slave-function interface board for operation on MCB (Multi-channel Bus developed by Kikusui). By using MC11S interface in conjunction with master-function interface such as IB11 (GPIB) or RS11 (RS-232C) interface, you can make up a system consisting of up to 16 units of Power Supplies and/or Electronic Loads. Before start using these instruments, read this manual and that of the instrument on which the MC11S is to be installed.

- Caution** • In the text of this manual, term "MC11S" denotes the MCB Slave Serial Interface and term "main instrument" denotes the Power Supply or Electronic Load on which the MC11S is to be installed.

1.2 Applicable Series

The MC11S is applicable to the following series of instruments:

- 1) PAX Series
- 2) PBX Series
- 3) PLZ-3W Series
- 4) PAD-LET Series
- 5) Other instruments as specified elsewhere

Chapter 2. PREPARATION

2.1 Installing the MC11S

Insert the MC11S into the interface board slot of the main instrument and fix the MC11S to the main instrument with the two installation bolts.

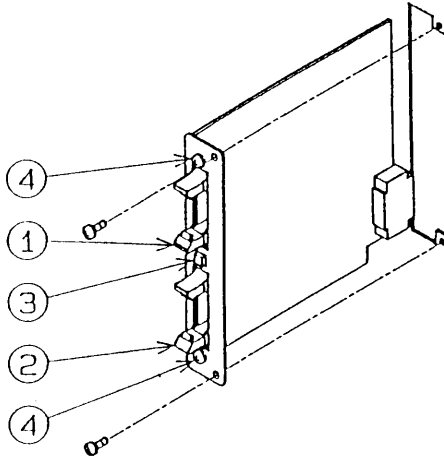

- WARNINGS**
- Before installing the MC11S on the main instrument, be sure to turn-off the POWER switch of the main instrument and disconnect its AC power cable from the AC line.
 - Do not touch the electrically conductive parts of the MC11S. If you do this, internal electronic parts can be damaged by static electricity.

- Caution**
- Be sure to install the MC11S in the correct direction as illustrated above.
 - For the location of the interface board slot of the main instrument, refer to the operation manual of the main instrument.

2.2 Description of Connectors and Switch

- ① MCB IN connector : The input connector for MCB (Multi-channel Bus). To be connected to the MCB connector of IB11/RS11 interface board or to the MCB OUT connector of other MC11S. For connection, securely insert the connector of the MCB cable and fix it with the lever.

- ② MCB IN connector : The output connector for MCB (Multi-channel Bus). To be connected to the MCB IN connector of other MC11S. For connection, securely insert the connector of the MCB cable and fix it with the lever.

- NOTE** • When connecting the cable, remove the dummy socket.

- ③ TERM switch : The push switch for loading or unloading the cable with terminator resistor.

- ④ Frame ground terminals : These terminals are connected to the casing of the main instrument.

2.3 Setting the Short Plugs (S3)

Set the Short pin at Short plug S3-5 on the MC11S. For the location of the Short plugs, refer to Appendix "External Views and Overall Dimensions" at the end of this manual.

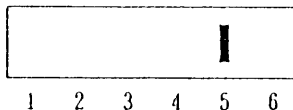

Caution

- Do not set the Short pin at other than S3-5. If you do it, the MS11S may not operate properly. (The factory default is S3-5.)

2.4 Loading/Unloading with Terminator Resistor

In order to improve the transmission characteristics of the MCB cables, the cable of the terminal MC11S (one whose MCB OUT connector has no cable connected to it) should be loaded with the terminator resistor while that of other MC11S (one or ones whose MCB OUT connector has a cable connected to it) should not be loaded with the terminator resistor. Load or unload the cable with the TERM switch as follows:

- To load (for terminal MC11S) : Set the TERM switch to "ON"
- To unload (for other MC11S) : Set the TERM switch to "OFF"

2.5 Connecting the Interface Boards with Cables

With MCB cables, connect between OUT connector and IN connectors of mutually adjoining interface boards sequentially, as illustrated below for example.

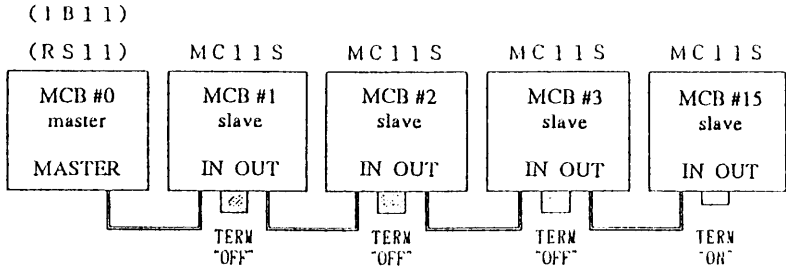

WARNINGS

- Before connecting the cables, be sure to turn-off power of the main instruments.
- Connect the shielding ground wire (green) of each cable to the frame ground terminal of of the MC11S.

NOTE

- The IB11 (GPIB) and RS11 (RS-232C) interface boards are optional.

2.6 Setting the Device Address

The address for each slave device can be set from the main instrument. For the setting procedure, refer to the operation manual of the main instrument.

Caution

- For the address number of a slave device, you can select from 1 to 15. You cannot specified the same address number for two or more devices.
- For remote programming, the address numbers of slave MCB devices can be specified with the [PATH] command. [PATH 0] is to specify the master IB11/RS11 device; [PATH 16] is to specify all MCB devices.

Chapter 3. STARTUP AND TEST

3.1 Turning-on Power

After correctly installing the MC11S, turn-on power of the main instrument and check the sign-on display on the main instrument. The sign-on display may differ depending on the model of the main instrument, but will indicate installation of the MC11S as shown below for example--where the main instrument is PAX35-20 Power Supply.

P A X 3 5 - 2 0	V e r 1 . 0 0
M C 0 1	

- Message "MC01" on the bottom row means that the MC11S is installed. Argument "01" denotes the device address.
- For further details, refer to the operation manual of the main instrument.

Caution

- When operating the instruments on the MCB bus, turn-on power of all instruments. This is especially true for the terminal instrument whose cable is loaded with the terminal resistor.

3.2 Running a Test Program

Connect the GPIB or RS-232C cable and the MCB cable. Run the corresponding one of the programs given below, and see that the model number and ROM version number of the main instrument are returned in response.

(1) For a setup with IB11 and MC11S

```
REM $INCLUDE: 'abdecl.bas'
devname$ = "DEV1"
CALL ibfind(devname$, pax%)
CALL ibclr(pax%)           ' Initialize PS2 with MC-GPIB(NI-488.2)
wrt$ = "PATH 1:IDN ?"
CALL ibwrt(pax%, wrt$)    ' ID query
rd$ = SPACE$(40)
CALL ibrd(pax%, rd$)      ' Get ID string.
PRINT rd$                 ' Display the ID string.
END
```

Caution

- This program is an example with an IBM Personal computer PS2 and QuickBASIC.
- MCB slave device address is "1".
- For the setting procedures of MCB slave device address and GPIB device address, refer to the instruction manual of the main instrument.

(2) For a setup with RS11 and MC11S

```
OPEN "COM1:9600,N,8,2,ASC,CS0,DS0" FOR RANDOM AS #1 LEN = 128
                                     ' Set communication parameters
PRINT #1, "PATH 1:IDN ?"             ' IDN query
INPUT #1, ID$                        ' Get an ID string.
PRINT ID$                             ' Display the ID string.
END
```

Caution

- This program is an example with an IBM Personal Computer PS2 and QuickBASIC.
- MCB slave device address is "1".
- For the setting procedures of MCB slave device address and RS-232C communication parameters, refer to the instruction manual of the main instrument.
- PS2 is trademark of IBM Corporation.
- NI-488.2 is trademark of National Instruments Coporation.
- QuickBASIC is trademark of Microsoft Corporation.

Chapter 4. CHECKUP BEFORE ORDERING REPAIR

When the MC11S has become failed seemingly, check it as described in this section in order to make certain that it has actually failed.

Checkup Procedure

Symptoms	Items to be checked	Remedies
The sign-on display does not indicate the installation of MC11S.	Installation of the MC11S	Correctly install the MC11S.
The program message is not received or accepted by the main instrument.	Cable Device address Syntactical error of command	Correctly connect the cable. Correctly set the device address. Correct the command syntax.
No response message is returned.	Device address Wrong setting of terminator (delimiter) Syntactical error	Correctly set the device address. Correctly set the terminator (delimiter). Correct the syntax of the query.

Check the following once more:

- Have not you specified the same address for two or more devices?
 - Have you correctly connected the MCB cable between IN and OUT connectors of the interface boards?
 - Have you correctly set the TERM switches?
 - Are not you sending a command to an MCB device address which does not actually exist?
 - Have not you sent a command which is inhibited for the operation mode of the main instrument?
- © If the MC11S does not operate properly even after you have checked and corrected the above items, order your Kikusui agent for repair.

Chapter 5. SPECIFICATIONS

5.1 MCB (Slave Function) Section

5.1.1 Serial Communication

- 1) Between master and slave: Synchronized full-duplex, 9600 bps
- 2) Address designation system
- 3) ACK control system
- 4) Balanced transmission system (A terminator resistor can be loaded or unloaded with a push switch.)
- 5) ASCII: 8 bits

5.1.2 Control Lines

- 1) Non-balanced transmission system

5.1.3 Connectors (MCB IN and MCB OUT)

- 1) Model: XG4A-1434 of OMRON Corp. (or equivalent)
- 2) Pin assignment

Pin	Signal	Function
1	TXD-	"-" line of signal transmitted from master
2	TXD+	"+" line of signal transmitted from master
3	RXD-	"-" line of signal received to master
4	RXD+	"+" line of signal received to master
5	GND	Logic ground
6	CLK-	"-" line of clock signal for sync.
7	CLK+	"+" line of clock signal for sync.
8	GND	Logic ground
9	TLKRQ	Talk request signal (negative logic)
10	TLKAK	Talk acknowledge signal (negative logic)
11	TRG	Trigger control signal (negative logic)
12	NRDY	Global address response signal (negative logic)
13	CABLE	Cable connection signal (negative logic)
14	GND	Logic ground

5.1.4 Cables

- 1) Type of connectors: XG4M-1434 of OMRON Corp. (or equivalent)
- 2) Type of cables: BIOS cable of BANTO DENSEN Corp. (or equivalent)
- 3) Number of units: Up to 15 slave units per 1 master unit
- 4) Cable length: Up to 30 meters. (As a standard accessory, a 1 meter-long cable accompanies the MC11S.)

5.1.5 Interface Functions

- 1) Data send/receive function
(synchronized serial full-duplex communication)
- 2) Simultaneous trigger function
- 3) Protection synchronization function
- 4) Others

For these functions, refer to the operation manual of the main instrument.

5.1.6 Others

- 1) Address of slave MCB: 0 - 15 (can be set from main instrument)
- 2) Loading/unloading with terminator resistor is selectable with push switch.

5.2 Ambient Conditions

Operable temperature	: 0 to 50°C
Operable humidity	: 10 to 90% RH
Storage temperature	: -20 to 70°C
Storage humidity	: 10 to 90% RH

5.3 Withstanding Voltage and Insulation Resistances

- 1) Withstanding voltage
Output - main instrument : 1500 V AC, 1 minute
- 2) Insulation resistances
Output - chassis : $\geq 30 \text{ M}\Omega$, at 500 V DC
Main instrument - chassis : $\geq 30 \text{ M}\Omega$, at 500 V DC

Caution

- In the above, term "output" denotes the MCB or other interface side of MC11S and term "main instrument" denotes the main instrument side of MC11S.

5.4 Dimensions and Weight

Dimensions : As shown in Appendix "External Views and Overall Dimensions."

Weight : Approx. 150 g

5.5 Accessories

Dummy socket for MCB OUT connector	1 (installed)
MCB cable (1 meter long)	1
Installation bolts	2
Operation manual	1 copy

Appendix: EXTERNAL VIEWS AND OVERALL DIMENSIONS

[UNIT:mm]

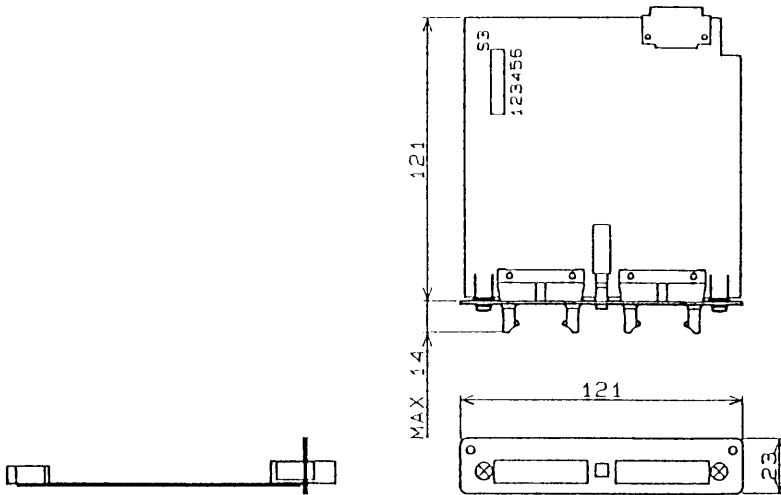

MC11S

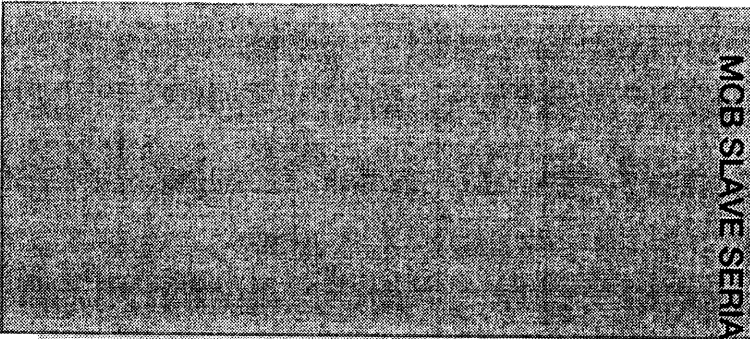

KIKUSUI ELECTRONICS CORP.

1-1-3, Higashiyamata, Tsuzuki-ku, Yokohama, 224-0023, Japan

Tel : 045-593-7570 Fax : 045-593-7571